



## Office

## TO LET

### Kestrel & Knightrider House

Knightrider Court, Maidstone, Kent ME15 6LU

Refurbished Town Centre Small Flexible Office  
Suites with parking

**Size** 150 to 750 sq ft (13.93 to 69.67 sq m)

COMING SOON

### Key Points

- Flexible lease terms
- 24 Hour access
- Town centre
- Air conditioning
- LED lighting
- Tea points
- 2 passenger lifts
- On site parking

## Location

Kestrel House and Kinightrider House are prominently situated on the southern side of Maidstone town centre with good access to J6 and J7 of the M20 within 2 miles. It is conveniently located for town centre amenities including The Mall and Fremlin Walk shopping centre. Maidstone East and West railway stations are within walking distance providing journey times into London Victoria, London Bridge and St Pancras stations within the hour.

## Description

Kestrel House is a modern four storey, high quality office building with double glazed windows, air conditioning, 2 passenger lifts, separate WC's to each floor and on site parking.

Kinightrider House is a three storey, office building with an impressive central staircase, kitchen, separate WC's and gated on site parking.

## Accommodation

The offices are bright and airy, with large windows that let in plenty of natural light in suite sizes between 150 to 750 sq ft.

Suites are available either individually or combined to suit your needs. High quality phone and broadband packages are provided and further information is available on request.

## Terms / Rent

Flexible lease terms. Further information on request.

## EPC

This property has been graded as 75(C).

## Legal Costs

Each party to bear its own costs.

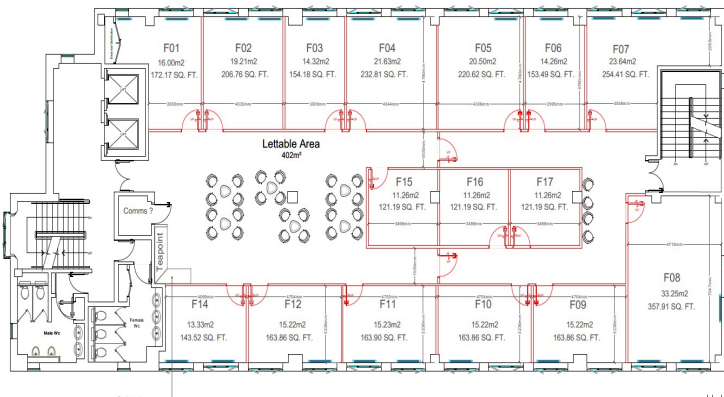
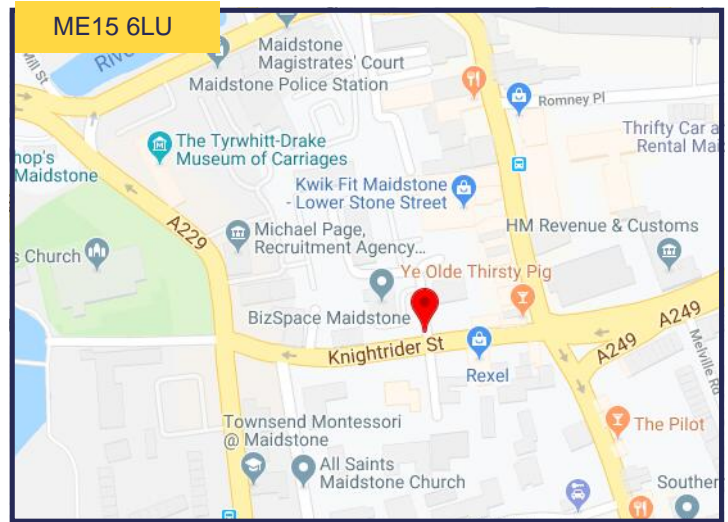

### Graham Starling

01622 672233  
07710 199901  
gs@martinewaghorn.co.uk



### Robert Martine

01622 672233  
07812 164698  
rmm@martinewaghorn.co.uk

[www.martinewaghorn.co.uk](http://www.martinewaghorn.co.uk)